

BT-ZX10

# QFX

WHERE THE PARTY BEGINS™



INSTRUCTION MANUAL



## Device Overview

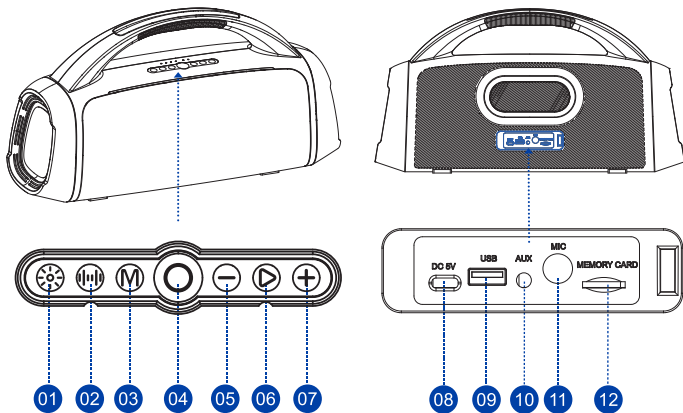

- 01-----LED Light Button
- 02-----Bass Button
- 03-----Mode Button
- 04-----Power Button
- 05-----Volume Down/Previous
- 06-----Play/Pause Button

- 07-----Volume Up/Next
- 08-----Type-c Input
- 09-----USB Input
- 10-----Aux Input
- 11-----Mic Input
- 12-----Memory Card Input

## Charging Your Device

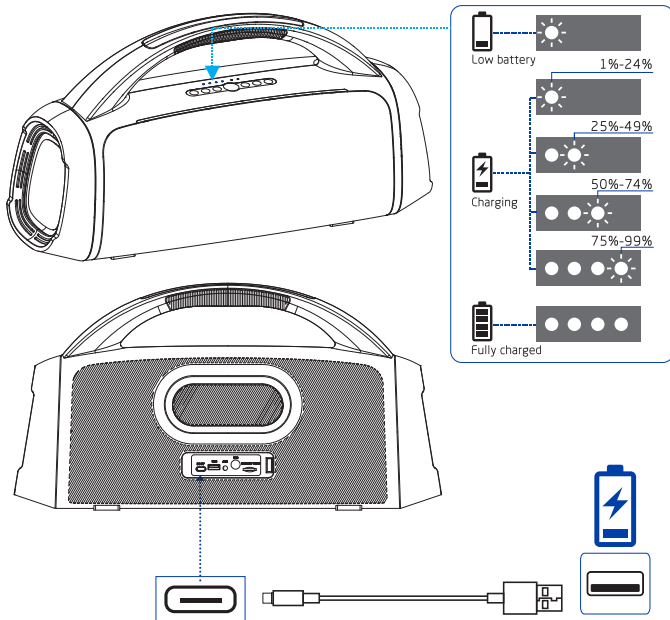

**Turn On/Off**

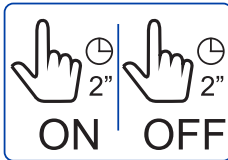
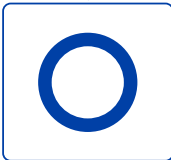
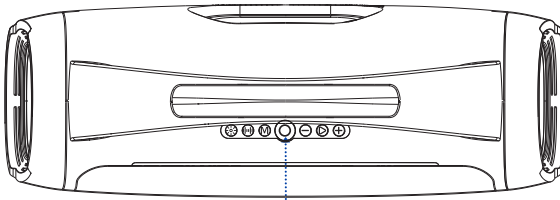

Press And Hold the POWER button 2 seconds to turn on/off the portable speaker.

**BT Connecting/Disconnection**

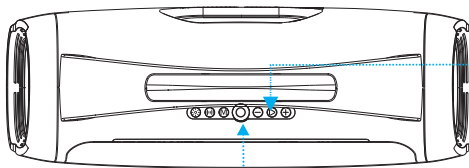

**BT Connection**

**01** **Press and Hold**  
 1. Press And Hold the Power button to enter BT pairing mode.  
 2. Search for the device name "QFX BT-ZX10" and tap to connect.

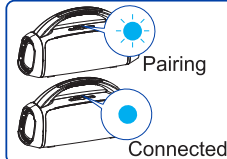

**BT Disconnection**

**Press and Hold**

Press And Hold "D" to disconnect the current device, and then enter BT pairing new device.

**Note:**

1. Automatically powers off after 10 minutes of no connection in BT mode.
2. Automatically powers off after 20 minutes of no playback or pause after connection.

**TWS Sync Mode**

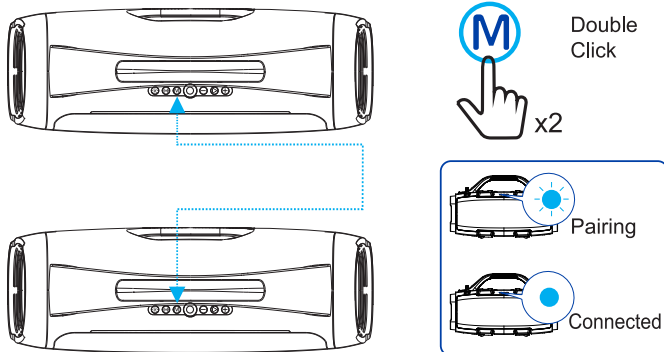

1. Turn on the two speakers and disconnect the BT connection.
2. Double-click "M" button on one speaker only, the purple lights of the main speakers flash alternately. After connecting, the purple lights will stay purple.
3. Search for BT device named "QFX BT-ZX10" and connected.

**NOTE:**

- \* Double-click "M" button to exit TWS mode. Press and hold the "M" button to change modes (BT, FM, USB, etc.).
- \* In TWS mode, turn off one of the speaker, both of them are off.

**Multi-function Mode**

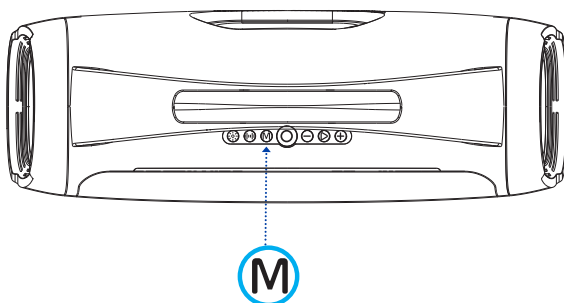

Short press (With microphone input)      Press and Hold >2"

<p>01</p> <p>microphone Volume</p> <p>Close      ECHO</p>	<p>02</p>	<p>BT</p> <p>FM      AUX      USB</p>
---	-----------	---------------------------------------

**Button Instruction**

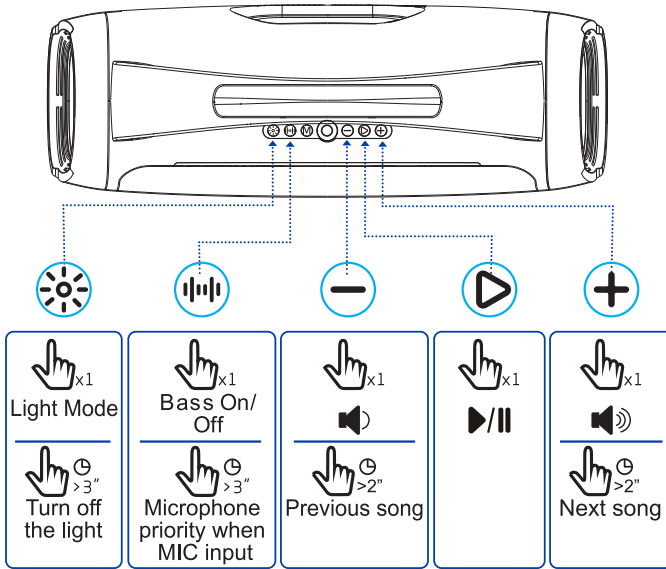

\* In FM mode: Press and hold the “- , +” button to change the channel; Press and hold the “▶” button for 2 seconds to search automatically

\* The AUX input is also acting as an FM antenna. The provided AUX cable can be used as an FM antenna by inserting it into the AUX port.

**Charging Out**

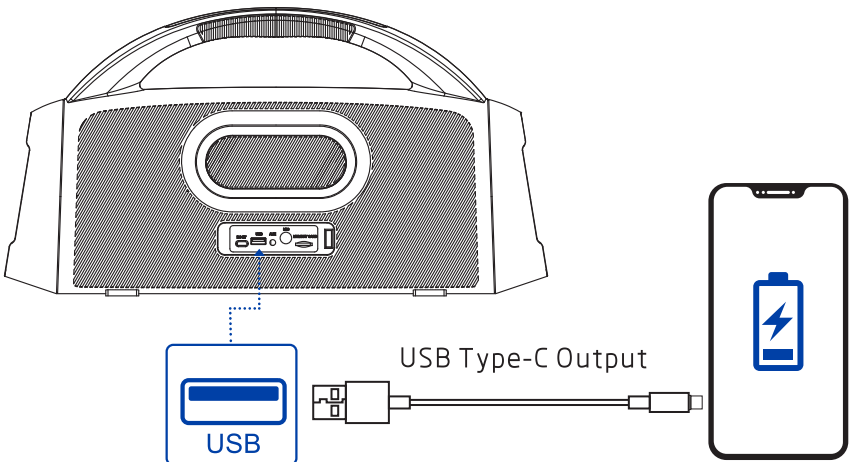

## **Specifications**

- Input Power: 5V— 2A
- Output Power 85W Peak
- Signal to Noise Ratio:  $\geq 78$ dB
- IPX6 water-resistant, spray proof
- Built-in rechargeable battery
- BT/AUX/USB/TF/MIC Function
- Frequency Response: 40Hz-20KHz
- TWS Sync Mode(True Wireless Stereo)
- Up to 10 hours of playtime (battery life is measured with volume set at 50%)

## **What's in the Box**

- 1\* Portable Party Speaker
- 1\* USB Charging Cable (Type-C)
- 1\* Quick Start Guide





## LIMITED PRODUCT WARRANTY POLICY

Before returning your Product for service under this Warranty, please (i) read the instruction manual carefully and visit our website at [www.qfxusa.com](http://www.qfxusa.com) for Product updates and extended support documentation (e.g., Common Troubleshooting Guides); (ii) if you are still having trouble with your Product, please contact the QFX Customer Support Department.

Subject to the terms and conditions herein, QFX, Inc. (herein after called "QFX") warrants to the original purchaser of the Product ("Customer") that for the applicable Warranty Period listed below, the Product will be free from defects in material or workmanship under normal, non-commercial use ("Defects").

Warranty Period encompasses, as listed below, separate "Coverage Periods" for Parts and Labor, each Coverage Period to begin from the original date of Customer purchase. If Customer returns a defective Product (or any component thereof) during the applicable Warranty Period, QFX will, at its option, during the specified Coverage Periods for Parts and Labor (as applicable either: (i) repair the Product (or, as applicable, any component thereof) or (ii) replace the Product (or, as applicable, any component thereof) with a new or refurbished Product (or, as applicable, any component thereof), in either case free of charge to Customer for Parts and/or Labor (as applicable) during the specified Coverage Period only, and excluding applicable shipping charges (noted below), for which the Customer is responsible. The foregoing states the Customer's exclusive remedy and QFX sole liability for breach of the limited warranty contained herein.

This warranty covers only normal use. This warranty is not transferable. QFX is not responsible for warranty replacement should the QFX label or logo be removed or should the product fail to be properly maintained or fail to function properly as a result of misuse, abuse, immersion in liquids, improper installation, improper shipping, damage caused by disasters such as fire, flood, or service other than by QFX. In addition, this warranty excludes any Product (or, as applicable, any component thereof) that has been subject to or Defects resulting from: (a) any neglect or misuse by a Customer, an accident, improper application, violation of operating instructions for the Product, any other Customer-induced damage, or the alteration or removal of any Product serial number; (b) any modification or repair to Product (or, as applicable, any component thereof) by any party other than QFX or a party authorized in writing by QFX; (c) any damage to Product (or, as applicable, any component thereof) due to power surges, incorrect electrical voltage, misconnection to any device, or malfunction of any device used with the Product (or, as applicable, any component thereof); (d) cosmetic damage to the Product (or, as applicable, any component thereof) caused by normal wear and tear; (e) shipping damage that occurs while the Product is in transit; (f) damage caused by heat sources, sunlight, electromagnetic conditions, or other climatic conditions or (g) any acts of God.

Product is sold to Customer for personal, non-commercial use only. Product is not warranted for Customer's commercial or rental use. In addition, Product is not warranted against failure, and should not be used by Customer for any application where (i) there is a risk that any data stored on Product will be breached or otherwise compromised, or (ii) the data stored on Product is relied upon for medical or lifesaving applications. QFX disclaims any Warranty for any of the foregoing uses to the fullest extent permitted by law. Customer assumes any and all risks associated with such uses of Product, and agrees to indemnify QFX for any damages claimed against QFX for such uses.

**EXCEPT FOR EXPRESS WARRANTIES STATED ABOVE AND TO THE MAXIMUM EXTENT PERMITTED BY LAW, THE PRODUCTS ARE PROVIDED "AS IS" AND QFX DISCLAIMS ALL OTHER WARRANTIES, INCLUDING WITHOUT LIMITATION ANY IMPLIED WARRANTY (I) OF MERCHANTABILITY, (II) OF FITNESS FOR A PARTICULAR PURPOSE, OR (III) OF NON-INFRINGEMENT OF THIRD PARTY RIGHTS. TO THE MAXIMUM EXTENT PERMITTED BY APPLICABLE LAW, IN NO EVENT WILL QFX BE LIABLE TO CUSTOMER OR ANY THIRD PARTY FOR ANY INDIRECT, SPECIAL, INCIDENTAL, CONSEQUENTIAL, EXEMPLARY OR PUNITIVE DAMAGES, INCLUDING, WITHOUT LIMITATION, ANY LOST PROFITS OR REVENUES, LOSS OR INACCURACY OF ANY DATA OR COST OF SUBSTITUTE GOODS, REGARDLESS OF THE THEORY OF LIABILITY (INCLUDING NEGLIGENCE) AND EVEN IF QFX HAS BEEN ADVISED OF THE POSSIBILITY OF SUCH DAMAGES, QFX AGGREGATE LIABILITY TO CUSTOMER FOR ACTUAL DIRECT DAMAGES FOR ANY CAUSE WHATSOEVER SHALL BE LIMITED TO THE CUMULATIVE PRODUCT FEES PAID BY THAT CUSTOMER FOR THE PRODUCTS CAUSING THE DAMAGES, IF ANY.**

This Warranty gives Customer specific rights, and Customer may also have other rights that vary from jurisdiction to jurisdiction. Warning: Some Products may contain components that are small enough to be swallowed. Please keep out of reach of children. In order for the return to be processed, you must send the Product PREPAID to the address below in the original packaging or reasonable substitute to prevent damage and include: (1) a dated sales receipt (which must have a purchase date that falls in the Warranty Period specified in the table below) that indicates the place of purchase, model number of Product, and amount paid, (2) a detailed description of Customer's problem with Product, (3) Customer's full name, phone number, and return address, (3) all of the accessories that came with the Product package must be sent along with the main Product, (4) a cashier's check or money order payable to QFX, Inc., in the amount specified for the item in the product table below for return shipping and handling. If in the case you cannot provide a money order or cashier's check, you can contact The QFX Customer Support Representative to arrange payment via credit card. No returned Product will be shipped back to a PO BOX. If a returned Product is found to have no problem and/or does not include ALL of the requirements indicated above, it may be returned back to the customer and will not be processed.

**QFX USA®**, Inc.  
 RMA Processing  
 Customer Support Department  
 2957 E. 46th Street | Vernon, CA 90058

📧 [support@qfxusa.com](mailto:support@qfxusa.com)  
 📞 (800) 864-CLUB (2582) or (323) 457-9900  
 🌐 [qfxusa.com](http://qfxusa.com)  
 🕒 Hours of Operation: Monday - Friday, 9am - 5pm PST

All prices and details below are for US Destinations excluding, Hawaii, Alaska and Puerto Rico. For excluded destinations and NON US destinations, please contact The QFX Customer Support Department directly for additional shipping fees and return instructions.

If you do not find your Product below, your Product model conflicts with multiple categories, and/or are unsure of which category the Product you have purchased will fall under, please contact our Customer Support Department for further instruction.

In order to determine the exact shipping cost that must be included with your product or paid for the product being returned, please refer to the table below. Please find the product you wish to return by category or model number prefix. QFX will not provide any return or refund to any customer for merchandise and will only honor the Limited Warranty restrictions mentioned in this document.

Please make sure to follow all directions prior to shipping back your item. If you are not sure what the shipping cost for your item is, or if your item category conflicts in the table below, please feel free to contact the QFX Support Department for further assistance.

PRODUCT CATEGORY	HANDLING	LABOR	PARTS
Earphones, Headphones, Pocket Radios, & Small Bluetooth Speakers	\$5.00	1 Year	1 Year
Personal Stereos	\$10.00	1 Year	1 Year
Portable Radio/Cassette	\$15.00	1 Year	1 Year
Large Portable Radio Cassette	\$20.00	1 Year	1 Year
Mobile Audio	\$10.00	1 Year	1 Year
Pro Audio SBX Systems	\$75.00	1 Year	1 Year
Pro Audio PBX Systems	\$75.00	1 Year	1 Year
Televisions	\$25.00	1 Year	1 Year
Telephones	\$10.00	1 Year	1 Year
Stand Fans	\$20.00	1 Year	1 Year
Portable Rechargeable Fans	\$15.00	1 Year	1 Year

THE WARRANTY AND REMEDY PROVIDED ABOVE ARE EXCLUSIVE AND IN LIEU OF ALL OTHER EXPRESSED OR IMPLIED WARRANTIES INCLUDING, BUT NOT LIMITED TO, THE IMPLIED WARRANTIES OF MERCHANTABILITY, NON-INFRINGEMENT OR FITNESS FOR A PARTICULAR PURPOSE. SOME LAWS DO NOT ALLOW THE EXCLUSION OF IMPLIED WARRANTIES. IF THESE LAWS APPLY, THEN ALL EXPRESSED OR IMPLIED WARRANTIES ARE LIMITED TO THE WARRANTY PERIOD IDENTIFIED ABOVE. UNLESS STATED HEREIN, ANY STATEMENT OR REPRESENTATIONS MADE BY ANY OTHER PERSONS OR FIRM ARE VOID. EXCEPT AS PROVIDED IN THIS WRITTEN WARRANTY, QFX SHALL NOT BE LIABLE FOR ANY LOSS, INCONVENIENCE, OR DAMAGE, INCLUDING DIRECT, SPECIAL, INCIDENTAL OR CONSEQUENTIAL DAMAGES, RESULTING FROM THE USE OR INABILITY TO USE THE QFX PRODUCT, WHETHER RESULTING FROM BREACH OF WARRANTY OR ANY OTHER LEGAL THEORY.

Some jurisdictions do not allow limitations on how long an implied warranty lasts, and some jurisdictions do not allow the exclusion or limitation of incidental or consequential damages, so the above limitations and exclusions may not apply to you. This warranty gives you special legal rights and you may have other rights which vary from jurisdiction to jurisdiction.

Copyright Protected 2025 ©



1-800-864-2582  
 Mon-Fri 9AM - 5PM (PST)



[support@qfxusa.com](mailto:support@qfxusa.com)  
 Mon-Fri 9AM - 5PM (PST)



[www.qfxusa.com](http://www.qfxusa.com)



# THANK YOU.

Enjoy your speaker and make many memories with it because  
**QFX is Where the Party Begins!**

We would love to hear about your BT-ZX10 Journey!  
Tag us **@QFXUSA** to share your stories.