

BT-1968

QFX

WHERE THE PARTY BEGINS™



INSTRUCTION MANUAL

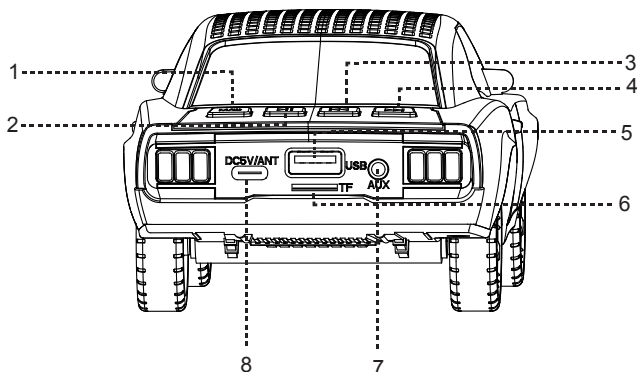

FUNCTIONS

- 1. POWER/MODE:** Press and hold to power ON or OFF. Short-press to toggle between modes (BT, USB/TF input, FM radio, AUX input).
- 2. ►||:** Short-press ►||to play/pause radio or BT or MP3 music. In FM mode, Press and hold ►||for auto-radio channel search. This operation will scan all FM stations and pre-record them into memory. The scan procedure may take several minutes and must not be interrupted. In BT mode, short-press to answer a phone call or Press and hold ►||to hang up the call. In BT mode, Press and hold ►||to redial last telephone number.
- 3. ▣/▽-:** Press and hold to lower volume. Short-press to listen to previous radio station or MP3 song.
- 4. ▣/▽+:** Press and hold to increase volume. Short-press to listen to next radio station or MP3 song.
- 5. USB:** Insert a USB drive with MP3 formatted music tracks.
- 6. TF:** Insert a TF CARD with MP3 formatted music tracks.
- 7. AXU:** 3.5mm input to connect external audio source
- 8. DC5V:** USB-C port for 5V charging.

FUNCTIONS

- 1. ENCENDIDO/NODO:** Mantenga presionado para encender o apagar. presione brevemente para alternar entre los modos(BT, entrada USB/TF, radio FM, entrada AUX).
- 2. ►||:** Presione brevemente para reproducir/pausar la radio o música BT o MP3. En el modo FM, mantenga presionado ►||para la búsqueda automática de canales de radio. Esta operación escaneará todas las estaciones de FM y las pregrabará en la memoria. El procedimiento de exploración puede tardar varios minutos y no debe interrumpirse. En el modo BT, presione brevemente para contestar una llamada telefónica o presione prolongadamente para colgar la llamada. En el modo BT, mantenga presionado ►||para volver a marcar el último número de teléfono.
- 3. ▣/▽-:** Mantenga pulsado para bajar el volumen. Presione brevemente para escuchar la estación de radio anterior o la canción MP3.
- 4. ▣/▽+:** Mantenga presionado para aumentar el volumen. Presione brevemente para escuchar la siguiente estación de radio o canción MP3.
- 5. USB:** una unidad USB con pistas de música en formato MP3. inserte
- 6. TF:** inserte una TARJETA TF con pistas de música en formato MP3.
- 7. AXU:** entrada de 3,5 mm para conectar de audio externa. una fuente
- 8. DC5V:** puerto USB-C para carga de 5V.

LES FONCTIONS

- 1. ALIMENTATION/MODE:** appuyez longuement pour allumer ou éteindre. Appuyez brièvement pour basculer entre les modes (BT, entrée USB/TF, radio FM, entrée AUX).
- 2. ►||:** Appuyez brièvement pour lire/mettre en pause la radio ou la musique BT ou MP3. En mode FM, appuyez longuement pour la recherche automatique des chaînes de radio. Cette opération balayera toutes les stations FM et les pré-enregistrera dans la mémoire. La procédure de numérisation peut prendre plusieurs minutes et ne doit pas être interrompue. En mode BT, appuyez ►|| brièvement pour répondre à un appel téléphonique ou appuyez longuement pour raccrocher. En mode BT, appuyez ►|| longuement pour recomposer le dernier numéro de téléphone.
- 3. ▣/▽-:** appuyez longuement pour baisser le volume. Appuyez brièvement pour écouter la station de radio précédente ou la chanson MP3.
- 4. ▣/▽+:** appuyez longuement pour augmenter le volume. Appuyez brièvement pour écouter la station de radio ou la chanson MP3 suivante.
- 5. USB:** insérez une clé USB contenant des morceaux de musique au format MP3.
- 6. TF:** insérez une carte TF avec des morceaux de musique au format MP3.
- 7. AXU:** entrée 3,5 mm pour connecter une source audio externe.
- 8. DC5V:** port USB-C pour une charge de 5 V

BLUETOOTH

Toggle MODE to select BT mode on the BT-1968. On your Bluetooth-enabled device, turn Bluetooth on, pair it to "QFX BT-1968" and enjoy Bluetooth music from your device.

TWS

True Wireless Stereo (TWS) allows you connect two BT-1968 units together to play Bluetooth music in wirelessly in stereo. To set up TWS:

1. Push MODE button on both speakers until both speakers are in BT mode.
2. When both speakers are in BT mode, press il button twice on one speaker only. You will hear a beep. Next time you put both speakers in Bluetooth mode at the same time, both speakers will connect automatically.

CHARGING

Plug in the USB cable to a 5VDC, 1 amp minimum source to recharge the internal battery. While charging, the rear tail lights will be solid red color. Once the unit is fully charged, the rear tail lights will be flashing.

CAUTION

Do not disassemble, short circuit, or expose unit to fire or hot temperatures. Recycle battery according to local state and national regulations.

BLUETOOTH

Alterne MODE para seleccionar el modo BT en el BT-1968. En su dispositivo habilitado para Bluetooth, active Bluetooth, conéctelo a "QFX BT-1968" y disfrute de la música Bluetooth desde su dispositivo.

TWS

True Wireless Stereo (TWS) le permite conectar dos unidades BT-1968 juntas para reproducir música Bluetooth de forma inalámbrica en estéreo. Para configurar TWS:

1. Presione el botón MODE en ambos parlantes hasta que ambos parlantes estén en modo BT.
2. Cuando ambos parlantes estén en modo BT, presione el botón ii dos veces en un solo parlante. Escuchará un pitido. La próxima vez que ponga ambos altavoces en modo Bluetooth al mismo tiempo, ambos altavoces se conectarán automáticamente.

CARGA

Conecte el cable USB a una fuente de 5 V CC, 1 amperio como mínimo para recargar la batería interna. Mientras se carga, las luces traseras traseras serán de color rojo sólido. Una vez que la unidad esté completamente cargada, las luces traseras parpadearán.

PRECAUCIÓN

No desarme, cortocircuite ni exponga la unidad al fuego o a altas temperaturas. Recicle la batería de acuerdo con las normas locales, estatales y nacionales.

BLUETOOTH

Basculez MODE pour sélectionner le mode BT sur le BT-1965. Sur votre appareil compatible Bluetooth, activez Bluetooth, associez-le à "QFX BT-1965" et profitez de la musique Bluetooth depuis votre appareil

TWS

True Wireless Stereo (TWS) vous permet de connecter deux unités BT-1965 ensemble pour lire de la musique Bluetooth sans fi en stéréo. Pour configurer TWS :

1. Appuyez sur le bouton MODE sur les deux haut-parleurs jusqu'à ce que les deux haut-parleurs soient en mode BT.
2. Lorsque les deux haut-parleurs sont en mode BT, appuyez rll deux fois sur le bouton d'un seul haut-parleur. Vous entendrez un bip. La prochaine fois que vous mettez les deux haut-parleurs en mode Bluetooth en même temps, les deux haut-parleurs se connecteront automatique- ment.

MISE EN CHARGE

Branchez le câble USB sur une source de 5 VDC, 1 A minimum pour recharger la batterie interne. Pendant la charge, les feux arrière seront de couleur rouge solide. Une fois l'appareil complètement chargé, les feux arrière clignoteront.

MISE EN GARGE

Ne pas démonter, court-circuiter ou exposer l'appareil au feu ou à des températures élevées. Recyclez la batterie conformément aux réglementations locales et nationales.



LIMITED PRODUCT WARRANTY POLICY

Before returning your Product for service under this Warranty, please (i) read the instruction manual carefully and visit our website at www.qfxusa.com for Product updates and extended support documentation (e.g., Common Troubleshooting Guides); (ii) if you are still having trouble with your Product, please contact the QFX Customer Support Department.

Subject to the terms and conditions herein, QFX, Inc. (herein after called "QFX") warrants to the original purchaser of the Product ("Customer") that for the applicable Warranty Period listed below, the Product will be free from defects in material or workmanship under normal, non-commercial use ("Defects").

Warranty Period encompasses, as listed below, separate "Coverage Periods" for Parts and Labor, each Coverage Period to begin from the original date of Customer purchase. If Customer returns a defective Product (or any component thereof) during the applicable Warranty Period, QFX will, at its option, during the specified Coverage Periods for Parts and Labor (as applicable either: (i) repair the Product (or, as applicable, any component thereof) or (ii) replace the Product (or, as applicable, any component thereof) with a new or refurbished Product (or, as applicable, any component thereof), in either case free of charge to Customer for Parts and/or Labor (as applicable) during the specified Coverage Period only, and excluding applicable shipping charges (noted below), for which the Customer is responsible. The foregoing states the Customer's exclusive remedy and QFX sole liability for breach of the limited warranty contained herein.

This warranty covers only normal use. This warranty is not transferable. QFX is not responsible for warranty replacement should the QFX label or logo be removed or should the product fail to be properly maintained or fail to function properly as a result of misuse, abuse, immersion in liquids, improper installation, improper shipping, damage caused by disasters such as fire, flood, or service other than by QFX. In addition, this warranty excludes any Product (or, as applicable, any component thereof) that has been subject to or Defects resulting from: (a) any neglect or misuse by a Customer, an accident, improper application, violation of operating instructions for the Product, any other Customer-induced damage, or the alteration or removal of any Product serial number; (b) any modification or repair to Product (or, as applicable, any component thereof) by any party other than QFX or a party authorized in writing by QFX; (c) any damage to Product (or, as applicable, any component thereof) due to power surges, incorrect electrical voltage, misconnection to any device, or malfunction of any device used with the Product (or, as applicable, any component thereof); (d) cosmetic damage to the Product (or, as applicable, any component thereof) caused by normal wear and tear; (e) shipping damage that occurs while the Product is in transit; (f) damage caused by heat sources, sunlight, electromagnetic conditions, or other climatic conditions or (g) any acts of God.

Product is sold to Customer for personal, non-commercial use only. Product is not warranted for Customer's commercial or rental use. In addition, Product is not warranted against failure, and should not be used by Customer for any application where (i) there is a risk that any data stored on Product will be breached or otherwise compromised, or (ii) the data stored on Product is relied upon for medical or lifesaving applications. QFX disclaims any Warranty for any of the foregoing uses to the fullest extent permitted by law. Customer assumes any and all risks associated with such uses of Product, and agrees to indemnify QFX for any damages claimed against QFX for such uses.

EXCEPT FOR EXPRESS WARRANTIES STATED ABOVE AND TO THE MAXIMUM EXTENT PERMITTED BY LAW, THE PRODUCTS ARE PROVIDED "AS IS" AND QFX DISCLAIMS ALL OTHER WARRANTIES, INCLUDING WITHOUT LIMITATION ANY IMPLIED WARRANTY (i) OF MERCHANTABILITY, (ii) OF FITNESS FOR A PARTICULAR PURPOSE, OR (iii) OF NON-INFRINGEMENT OF THIRD PARTY RIGHTS. TO THE MAXIMUM EXTENT PERMITTED BY APPLICABLE LAW, IN NO EVENT WILL QFX BE LIABLE TO CUSTOMER OR ANY THIRD PARTY FOR ANY INDIRECT, SPECIAL, INCIDENTAL, CONSEQUENTIAL, EXEMPLARY OR PUNITIVE DAMAGES, INCLUDING, WITHOUT LIMITATION, ANY LOST PROFITS OR REVENUES, LOSS OR INACCURACY OF ANY DATA OR COST OF SUBSTITUTE GOODS, REGARDLESS OF THE THEORY OF LIABILITY (INCLUDING NEGLIGENCE) AND EVEN IF QFX HAS BEEN ADVISED OF THE POSSIBILITY OF SUCH DAMAGES, QFX AGGREGATE LIABILITY TO CUSTOMER FOR ACTUAL DIRECT DAMAGES FOR ANY CAUSE WHATSOEVER SHALL BE LIMITED TO THE CUMULATIVE PRODUCT FEES PAID BY THAT CUSTOMER FOR THE PRODUCTS CAUSING THE DAMAGES, IF ANY.

This Warranty gives Customer specific rights, and Customer may also have other rights that vary from jurisdiction to jurisdiction. Warning: Some Products may contain components that are small enough to be swallowed. Please keep out of reach of children. In order for the return to be processed, you must send the Product PREPAID to the address below in the original packaging or reasonable substitute to prevent damage and include: (1) a dated sales receipt (which must have a purchase date that falls in the Warranty Period specified in the table below) that indicates the place of purchase, model number of Product, and amount paid, (2) a detailed description of Customer's problem with Product, (3) Customer's full name, phone number, and return address, (3) all of the accessories that came with the Product package must be sent along with the main Product, (4) a cashier's check or money order payable to QFX, Inc., in the amount specified for the item in the product table below for return shipping and handling. If in the case you cannot provide a money order or cashier's check, you can contact The QFX Customer Support Representative to arrange payment via credit card. No returned Product will be shipped back to a PO BOX. If a returned Product is found to have no problem and/or does not include ALL of the requirements indicated above, it may be returned back to the customer and will not be processed.

QFX USA®, Inc.
RMA Processing
Customer Support Department
2957 E. 46th Street | Vernon, CA 90058

support@qfxusa.com
(800) 864-CLUB (2582) or (323) 864-6900
qfxusa.com
Hours of Operation: Monday - Friday, 9am - 5pm PST

All prices and details below are for US Destinations excluding, Hawaii, Alaska and Puerto Rico. For excluded destinations and NON US destinations, please contact The QFX Customer Support Department directly for additional shipping fees and return instructions.

If you do not find your Product below, your Product model conflicts with multiple categories, and/or are unsure of which category the Product you have purchased will fall under, please contact our Customer Support Department for further instruction.

In order to determine the exact shipping cost that must be included with your product or paid for the product being returned, please refer to the table below. Please find the product you wish to return by category or model number prefix. QFX will not provide any return or refund to any customer for merchandise and will only honor the Limited Warranty restrictions mentioned in this document.

Please make sure to follow all directions prior to shipping back your item. If you are not sure what the shipping cost for your item is, or if your item category conflicts in the table below, please feel free to contact the QFX Support Department for further assistance.

PRODUCT CATEGORY	HANDLING	LABOR	PARTS
Earphones, Headphones, Pocket Radios, & Small Bluetooth vSpeakers	\$5.00	1 Year	1 Year
Personal Stereos	\$10.00	1 Year	1 Year
Portable Radio/Cassette	\$15.00	1 Year	1 Year
Large Portable Radio Cassette	\$20.00	1 Year	1 Year
Mobile Audio	\$10.00	1 Year	1 Year
Pro Audio SBX Systems	\$75.00	1 Year	1 Year
Pro Audio PBX Systems	\$75.00	1 Year	1 Year
Televisions	\$25.00	1 Year	1 Year
Telephones	\$10.00	1 Year	1 Year

THE WARRANTY AND REMEDY PROVIDED ABOVE ARE EXCLUSIVE AND IN LIEU OF ALL OTHER EXPRESSED OR IMPLIED WARRANTIES INCLUDING, BUT NOT LIMITED TO, THE IMPLIED WARRANTIES OF MERCHANTABILITY, NON-INFRINGEMENT OR FITNESS FOR A PARTICULAR PURPOSE. SOME LAWS DO NOT ALLOW THE EXCLUSION OF IMPLIED WARRANTIES. IF THESE LAWS APPLY, THEN ALL EXPRESSED OR IMPLIED WARRANTIES ARE LIMITED TO THE WARRANTY PERIOD IDENTIFIED ABOVE. UNLESS STATED HEREIN, ANY STATEMENT OR REPRESENTATIONS MADE BY ANY OTHER PERSONS OR FIRM ARE VOID. EXCEPT AS PROVIDED IN THIS WRITTEN WARRANTY, QFX SHALL NOT BE LIABLE FOR ANY LOSS, INCONVENIENCE, OR DAMAGE, INCLUDING DIRECT, SPECIAL, INCIDENTAL OR CONSEQUENTIAL DAMAGES, RESULTING FROM THE USE OR INABILITY TO USE THE QFX PRODUCT, WHETHER RESULTING FROM BREACH OF WARRANTY OR ANY OTHER LEGAL THEORY.

Some jurisdictions do not allow limitations on how long an implied warranty lasts, and some jurisdictions do not allow the exclusion or limitation of incidental or consequential damages, so the above limitations and exclusions may not apply to you. This warranty gives you special legal rights and you may have other rights which vary from jurisdiction to jurisdiction.

Copyright Protected 2023 ©



1-800-864-CLUB (2582)
Mon-Fri 9AM - 5PM (PST)



support@qfxusa.com
Mon-Fri 9AM - 5PM (PST)



www.qfxusa.com

THANK YOU.

Enjoy your speaker and make many memories with it because
QFX is Where the Party Begins!

We would love to hear about your BT-1968 Journey!
Tag us **@QFXUSA** to share your stories.