

QFX[®]

WHERE THE PARTY BEGINS[™]



INSTRUCTION MANUAL

**WARNING!**

TO REDUCE THE RISK OF ELECTRIC SHOCK, DO NOT REMOVE THE COVER ON THIS SPEAKER. THERE ARE NO USER-SERVICEABLE PARTS INSIDE. REFER ALL SERVICING TO A QUALIFIED TECHNICIAN

To prevent fire or electric shock, do not expose this equipment to rain or moisture. Do not store or operate this product near any liquids, heat sources such as radiators, heat registers or under extreme weather conditions. Clean only with a dry cloth.

Users should exhibit extra safety when the WARNING or CAUTION symbol appears in this instruction manual and follow all precautions as they are stated.

**¡ADVERTENCIA!**

PARA REDUCIR EL RIESGO DE DESCARGA ELÉCTRICA, NO RETIRE LA CUBIERTA DE ESTE ALTAVOZ. NO HAY PARTES REPARABLES POR EL USUARIO ADENTRO. REFIERA TODAS LAS REPARACIONES A UN TÉCNICO CALIFICADO

Para evitar incendios o descargas eléctricas, no exponga este equipo a la lluvia ni a la humedad. No almacene ni utilice este producto cerca de líquidos, fuentes de calor como radiadores, rejillas de calefacción o bajo condiciones climáticas extremas. Limpie solamente con un paño seco.

Los usuarios deben exhibir una seguridad adicional cuando aparezca el símbolo de ADVERTENCIA o PRECAUCIÓN en este manual de instrucciones y seguir todas las precauciones indicadas.

**WARNING!**

POUR RÉDUIRE LE RISQUE DE CHOC ÉLECTRIQUE, NE RETIREZ PAS LE COUVERCLE DE CET HAUT-PARLEUR. IL N'Y A AUCUNE PIÈCE RÉPARABLE PAR L'UTILISATEUR À L'INTÉRIEUR. RÉFÉREZ TOUTE RÉPARATION À UN TECHNICIEN QUALIFIÉ

Pour éviter tout incendie ou choc électrique, n'exposez pas cet équipement à la pluie ou à l'humidité. Ne stockez pas et n'utilisez pas ce produit à proximité de liquides, de sources de chaleur telles que radiateurs, bouches de chaleur ou dans des conditions météorologiques extrêmes. Nettoyez uniquement avec un chiffon sec.

Les utilisateurs doivent faire preuve d'une sécurité supplémentaire lorsque le symbole AVERTISSEMENT ou ATTENTION apparaît dans ce manuel d'instructions et suivre toutes les précautions telles qu'elles sont énoncées.

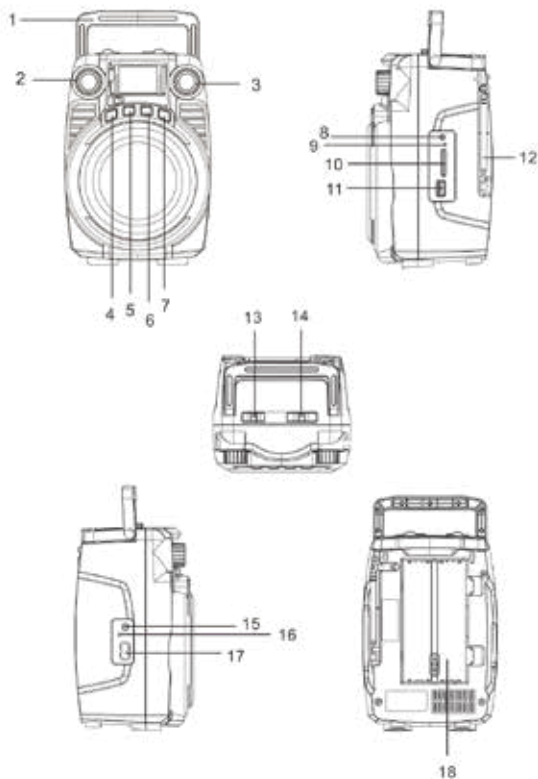
FUNCTIONS

1. HANDLE
2. VOLUME
3. TUNING
4. REPEAT
5. PREV/REW
6. PLAY/PAUSE
7. NEXT/FAST FWD
8. AUX IN
9. USB POWER INDICATOR
10. SD CARD
11. USB DIRECT
12. ROD ANTENNA
13. FUNCTION SWITCH
14. BAND SWITCH
15. DC IN
16. CHARGING INDICATOR
17. AC IN
18. BATTERY DOOR

FUNCIONES

1. MANIPULER
2. LE VOLUME
3. RÉGLAGE
4. RÉPÉTER
5. PRÉCÉDENT/LIGNE
6. JOUER PAUSE
7. SUIVANT/AVANT RAPIDE
8. ENTRÉE AUXILIAIRE
9. VOYANT D'ALIMENTATION USB
10. CARTE SD
11. USB DIRECT
12. ANTENNE BARRE
13. COMMUTATEUR DE FONCTION
14. COMMUTATEUR DE BANDE
15. ENTRÉE CC
16. INDICATEUR DE CHARGE
17. ENTRÉE CA
18. PORTE BATTERIE

LES FONCTIONS

1. RESOLVER
2. VOLUMEN
3. AFINACIÓN
4. REPETIR
5. ANTERIOR/FILA
6. REPRODUCIR PAUSAR
7. SIGUIENTE/AVANCE RÁPIDO
8. ENTRADA AUX
9. INDICADOR DE ALIMENTACIÓN USB
10. TARJETA SD
11. USB DIRECTO
12. ANTENA DE VARILLA
13. INTERRUPTOR DE FUNCIÓN
14. CAMBIO DE BANDA
15. DC EN
16. INDICADOR DE CARGA
17. ENTRADA DE CA
18. TAPA DE LA BATERÍA

RADIO

1. Change the function switch to the desired radio band AM, FM or SW.
2. Adjust the volume and turn the radio dial to the preferred radio station.
3. Pull the antenna out and adjust it to receive the best FM or SW reception.

USB/TF MUSIC PLAYER

1. Move the function switch to the USB/AUX position.
2. Insert the USB/TF card to play MP3 music files stored on USB flash drive or TF card.
3. It will automatically start to play the first song.
4. Use Play/Pause, Next/FFwd, Prev/Rewind buttons to control music playback.

BLUETOOTH

1. Switch the function switch to Bluetooth and you will hear a voice saying "waiting for the pairing"
 2. Open Bluetooth settings on your mobile phone, scan and select "QFX BT-44" to pair.
 3. Confirm pairing on your device and a voice prompt will confirm pairing was successful.
 4. Now you can play and control music stored on your mobile phone.
-

RADIO

1. Cambie el interruptor de función a la banda de radio deseada AM, FM o SW.
2. Ajuste el volumen y gire el dial de la radio a la estación de radio preferida.
3. Saque la antena y ajústela para recibir la mejor recepción de FM o SW.

REPRODUCTOR DE MÚSICA USB/TF

1. Mueva el interruptor de función a la posición USB/AUX.
2. Inserte la tarjeta USB/TF para reproducir archivos de música MP3 almacenados en una unidad flash USB o tarjeta TF.
3. Automáticamente comenzará a reproducir la primera canción.
4. Utilice los botones Reproducir/Pausar, Siguiente/Avanzar, Anterior/Retroceder para controlar la reproducción de música.

BLUETOOTH

1. Cambie el interruptor de función a Bluetooth y escuchará una voz que dice "esperando el emparejamiento"
 2. Abra la configuración de Bluetooth en su teléfono móvil, escanee y seleccione "QFX BT-44" para emparejar.
 3. Confirme el emparejamiento en su dispositivo y un mensaje de voz confirmará que el emparejamiento fue exitoso.
 4. Ahora puedes reproducir y controlar la música almacenada en tu teléfono móvil.
-

RADIO

1. Réglez le commutateur de fonction sur la bande radio souhaitée AM, FM ou SW.
2. Réglez le volume et tournez le cadran de la radio sur la station de radio préférée.
3. Sortez l'antenne et réglez-la pour recevoir la meilleure réception FM ou SW.

LECTEUR DE MUSIQUE USB/TF

1. Déplacez le commutateur de fonction sur la position USB/AUX.
2. Insérez la carte USB/TF pour lire des fichiers musicaux MP3 stockés sur une clé USB ou une carte TF.
3. Il commencera automatiquement à jouer la première chanson.
4. Utilisez les boutons Play/Pause, Next/FFwd, Prev/Rewind pour contrôler la lecture de la musique.

BLUETOOTH

1. Basculez le commutateur de fonction sur Bluetooth et vous entendrez une voix disant "en attente de l'appairage"
2. Ouvrez les paramètres Bluetooth sur votre téléphone portable, scannez et sélectionnez "QFX BT-44" pour coupler.
3. Confirmez le jumelage sur votre appareil et une invite vocale confirmera que le jumelage a réussi.
4. Vous pouvez désormais lire et contrôler la musique stockée sur votre téléphone portable.



LIMITED PRODUCT WARRANTY POLICY

Before returning your Product for service under this Warranty, please (i) read the instruction manual carefully and visit our website at www.qfxusa.com for Product updates and extended support documentation (e.g., Common Troubleshooting Guides); (ii) if you are still having trouble with your Product, please contact the QFX Customer Support Department.

Subject to the terms and conditions herein, QFX, Inc. (herein after called "QFX") warrants to the original purchaser of the Product ("Customer") that for the applicable Warranty Period listed below, the Product will be free from defects in material or workmanship under normal, non-commercial use ("Defects").

Warranty Period encompasses, as listed below, separate "Coverage Periods" for Parts and Labor, each Coverage Period to begin from the original date of Customer purchase. If Customer returns a defective Product (or any component thereof) during the applicable Warranty Period, QFX will, at its option, during the specified Coverage Periods for Parts and Labor (as applicable either: (i) repair the Product (or, as applicable, any component thereof) or (ii) replace the Product (or, as applicable, any component thereof) with a new or refurbished Product (or, as applicable, any component thereof), in either case free of charge to Customer for Parts and/or Labor (as applicable) during the specified Coverage Period only, and excluding applicable shipping charges (noted below), for which the Customer is responsible. The foregoing states the Customer's exclusive remedy and QFX sole liability for breach of the limited warranty contained herein.

This warranty covers only normal use. This warranty is not transferable. QFX is not responsible for warranty replacement should the QFX label or logo be removed or should the product fail to be properly maintained or fail to function properly as a result of misuse, abuse, immersion in liquids, improper installation, improper shipping, damage caused by disasters such as fire, flood, or service other than by QFX. In addition, this warranty excludes any Product (or, as applicable, any component thereof) that has been subject to or Defects resulting from: (a) any neglect or misuse by a Customer, an accident, improper application, violation of operating instructions for the Product, any other Customer-induced damage, or the alteration or removal of any Product serial number; (b) any modification or repair to Product (or, as applicable, any component thereof) by any party other than QFX or a party authorized in writing by QFX; (c) any damage to Product (or, as applicable, any component thereof) due to power surges, incorrect electrical voltage, misconnection to any device, or malfunction of any device used with the Product (or, as applicable, any component thereof); (d) cosmetic damage to the Product (or, as applicable, any component thereof) caused by normal wear and tear; (e) shipping damage that occurs while the Product is in transit; (f) damage caused by heat sources, sunlight, electromagnetic conditions, or other climatic conditions or (g) any acts of God.

Product is sold to Customer for personal, non-commercial use only. Product is not warranted for Customer's commercial or rental use. In addition, Product is not warranted against failure, and should not be used by Customer for any application where (i) there is a risk that any data stored on Product will be breached or otherwise compromised, or (ii) the data stored on Product is relied upon for medical or lifesaving applications. QFX disclaims any Warranty for any of the foregoing uses to the fullest extent permitted by law. Customer assumes any and all risks associated with such uses of Product, and agrees to indemnify QFX for any damages claimed against QFX for such uses.

EXCEPT FOR EXPRESS WARRANTIES STATED ABOVE AND TO THE MAXIMUM EXTENT PERMITTED BY LAW, THE PRODUCTS ARE PROVIDED "AS IS" AND QFX DISCLAIMS ALL OTHER WARRANTIES, INCLUDING WITHOUT LIMITATION ANY IMPLIED WARRANTY (i) OF MERCHANTABILITY, (ii) OF FITNESS FOR A PARTICULAR PURPOSE, OR (iii) OF NON-INFRINGEMENT OF THIRD PARTY RIGHTS. TO THE MAXIMUM EXTENT PERMITTED BY APPLICABLE LAW, IN NO EVENT WILL QFX BE LIABLE TO CUSTOMER OR ANY THIRD PARTY FOR ANY INDIRECT, SPECIAL, INCIDENTAL, CONSEQUENTIAL, EXEMPLARY OR PUNITIVE DAMAGES, INCLUDING, WITHOUT LIMITATION, ANY LOST PROFITS OR REVENUES, LOSS OR INACCURACY OF ANY DATA OR COST OF SUBSTITUTE GOODS, REGARDLESS OF THE THEORY OF LIABILITY (INCLUDING NEGLIGENCE) AND EVEN IF QFX HAS BEEN ADVISED OF THE POSSIBILITY OF SUCH DAMAGES, QFX AGGREGATE LIABILITY TO CUSTOMER FOR ACTUAL DIRECT DAMAGES FOR ANY CAUSE WHATSOEVER SHALL BE LIMITED TO THE CUMULATIVE PRODUCT FEES PAID BY THAT CUSTOMER FOR THE PRODUCTS CAUSING THE DAMAGES, IF ANY.

This Warranty gives Customer specific rights, and Customer may also have other rights that vary from jurisdiction to jurisdiction. Warning: Some Products may contain components that are small enough to be swallowed. Please keep out of reach of children. In order for the return to be processed, you must send the Product PREPAID to the address below in the original packaging or reasonable substitute to prevent damage and include: (1) a dated sales receipt (which must have a purchase date that falls in the Warranty Period specified in the table below) that indicates the place of purchase, model number of Product, and amount paid, (2) a detailed description of Customer's problem with Product, (3) Customer's full name, phone number, and return address, (3) all of the accessories that came with the Product package must be sent along with the main Product, (4) a cashier's check or money order payable to QFX, Inc., in the amount specified for the item in the product table below for return shipping and handling. If in the case you cannot provide a money order or cashier's check, you can contact The QFX Customer Support Representative to arrange payment via credit card. No returned Product will be shipped back to a PO BOX. If a returned Product is found to have no problem and/or does not include ALL of the requirements indicated above, it may be returned back to the customer and will not be processed.

QFX USA, Inc.
RMA Processing
Customer Support Department
2957 E. 46th Street | Vernon, CA 90058

support@qfxusa.com
(800) 864-CLUB (2582) or (323) 864-6900
qfxusa.com
Hours of Operation: Monday - Friday, 9am - 5pm PST

All prices and details below are for US Destinations excluding, Hawaii, Alaska and Puerto Rico. For excluded destinations and NON US destinations, please contact The QFX Customer Support Department directly for additional shipping fees and return instructions.

If you do not find your Product below, your Product model conflicts with multiple categories, and/or are unsure of which category the Product you have purchased will fall under, please contact our Customer Support Department for further instruction.

In order to determine the exact shipping cost that must be included with your product or paid for the product being returned, please refer to the table below. Please find the product you wish to return by category or model number prefix. QFX will not provide any return or refund to any customer for merchandise and will only honor the Limited Warranty restrictions mentioned in this document.

Please make sure to follow all directions prior to shipping back your item. If you are not sure what the shipping cost for your item is, or if your item category conflicts in the table below, please feel free to contact the QFX Support Department for further assistance.

PRODUCT CATEGORY	HANDLING	LABOR	PARTS
Earphones, Headphones, Pocket Radios, & Small Bluetooth vSpeakers	\$5.00	1 Year	1 Year
Personal Stereos	\$10.00	1 Year	1 Year
Portable Radio/Cassette	\$15.00	1 Year	1 Year
Large Portable Radio Cassette	\$20.00	1 Year	1 Year
Mobile Audio	\$10.00	1 Year	1 Year
Pro Audio SBX Systems	\$75.00	1 Year	1 Year
Pro Audio PBX Systems	\$75.00	1 Year	1 Year
Televisions	\$25.00	1 Year	1 Year
Telephones	\$10.00	1 Year	1 Year

THE WARRANTY AND REMEDY PROVIDED ABOVE ARE EXCLUSIVE AND IN LIEU OF ALL OTHER EXPRESSED OR IMPLIED WARRANTIES INCLUDING, BUT NOT LIMITED TO, THE IMPLIED WARRANTIES OF MERCHANTABILITY, NON-INFRINGEMENT OR FITNESS FOR A PARTICULAR PURPOSE. SOME LAWS DO NOT ALLOW THE EXCLUSION OF IMPLIED WARRANTIES. IF THESE LAWS APPLY, THEN ALL EXPRESSED OR IMPLIED WARRANTIES ARE LIMITED TO THE WARRANTY PERIOD IDENTIFIED ABOVE. UNLESS STATED HEREIN, ANY STATEMENT OR REPRESENTATIONS MADE BY ANY OTHER PERSONS OR FIRM ARE VOID. EXCEPT AS PROVIDED IN THIS WRITTEN WARRANTY, QFX SHALL NOT BE LIABLE FOR ANY LOSS, INCONVENIENCE, OR DAMAGE, INCLUDING DIRECT, SPECIAL, INCIDENTAL OR CONSEQUENTIAL DAMAGES, RESULTING FROM THE USE OR INABILITY TO USE THE QFX PRODUCT, WHETHER RESULTING FROM BREACH OF WARRANTY OR ANY OTHER LEGAL THEORY.

Some jurisdictions do not allow limitations on how long an implied warranty lasts, and some jurisdictions do not allow the exclusion or limitation of incidental or consequential damages, so the above limitations and exclusions may not apply to you. This warranty gives you special legal rights and you may have other rights which vary from jurisdiction to jurisdiction.

Copyright Protected 2022 ©



www.qfxusa.com



1-800-864-CLUB (2582)
Mon-Fri 9AM - 5PM (PST)



support@qfxusa.com
Mon-Fri 9AM - 5PM (PST)

THANK YOU.

QFX Where the Party Begins!

We would love to hear about your BT-44 journey!
Tag us **@QFXUSA** to share your stories.

FOLLOW US @QFXUSA

