

● Amplified TV Antenna

- Easy to install
- Receives all UHF TV channels
- Ideal for 'free-to-view' digital terrestrial TV
- Gain 8-10 dB
- Low noise amplifier <1.5dB
- Standing wave ratio <2
- Impedance:75Ω

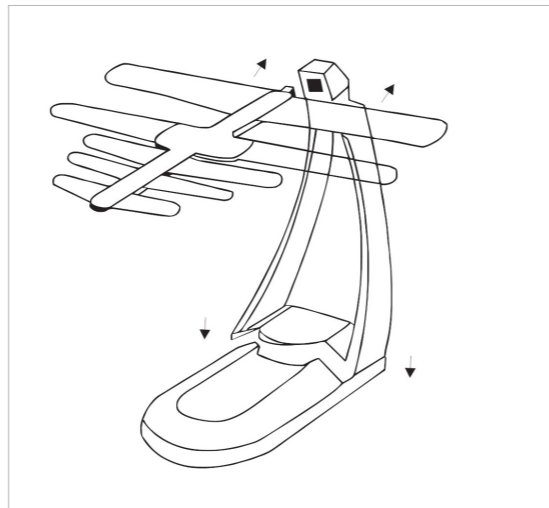

● Antena TV Amplificada

- Fácil de instalar
- Recibe todos los Canales UHF TV
- Ideal para "libre-de-ver" TV digital terrestre
- Ganancia 8 – 10 dB
- Amplificador bajo en ruido <1.5dB
- Relación de onda estacionaria <2
- Impedancia 75(w/Symbol)

